

WOLF[®] BIG 'O'

PARTS AND SERVICE MANUAL

6th Edition, Published July 2008

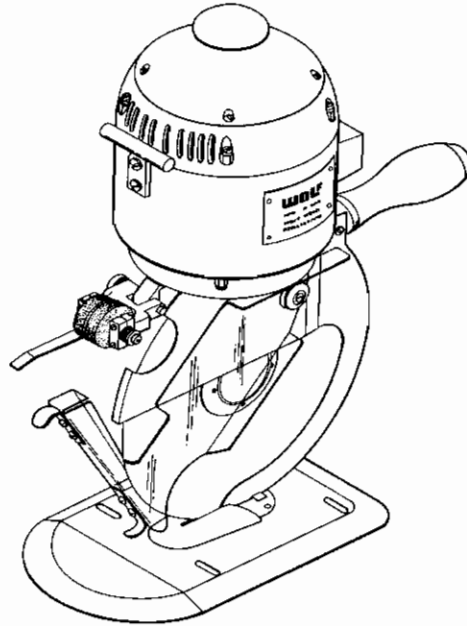

SERVICE INSTRUCTIONS

WARNING

This is a hazardous type of machinery and should be used with care. Always disconnect electrical connector before performing repairs, adjustments or maintenance. Be sure machine is properly grounded. Never place hands or any part of your person in the path of the machine when it's in service. Keep the front guard as low as possible during operation and completely down when not in use. For personal safety the operator should remove all loose fitting jewelry, shouldn't wear loose or baggy fitting clothing and persons with long hair should cover or pull it back.

Keep the machine clean and properly adjusted, as this will add to its life and efficiency. When ordering replacement parts be sure to give Part No., description and machine size.

MOTOR ROTATION

Before placing three phase machines in service be sure the knife rotates in a counter-clockwise direction when looking at the nameplate side of the machine. The rotation can be checked by a flash contact at the electrical connector with the switch turned on. To reverse direction, interchange two wires (not ground wire) at electrical connector.

CAUTION Should the machine be run in the wrong direction parts could unscrew and damage machine. Single phase machines always rotate in the proper direction.

LUBRICATION

The grease cup in the standard should be half filled with grease. Use only a good grade of cup grease.

To oil sharpener journals, remove screw in end of bushing shaft and oil. Keep emery free from oil and grease. To do this, remove emery and rub wheels together until they show a good surface, or spray with Keep-M-Kleen solution (Order #2100600).

TO SHARPEN KNIFE

It is most essential that a keen cutting edge be kept on the knife at all times, as this insures clean and easy cutting. To obtain this, the grinding wheels must be kept properly adjusted. Because of the wear of knife and emery wheels, it is necessary to adjust emeries toward the knife to avoid long bevel. Wheels must touch knife evenly. Adjustment is made by releasing screws clamping the threaded journals. The journals can then be turned to the proper position. Care should be taken that the emery wheels do not go too far down on knife. A good bevel of 1/8" makes a good cutting edge. Emeries must spin free at all times.

TO REMOVE KNIFE

To remove knife, place pin in hole through standard. Use knife wrench and turn knife nut to left. When knife wears, move toeplate back so that knife is about 1/16" from end of slot. Be sure to tighten screws that secure toeplate.

TO REMOVE GEAR

To remove knife gear, have knife on gear. Then put pin in knife and standard and loosen grease cap with pin wrench. Remove knife and cap. Then remove screw and washer. The gear can then be lifted off. Be sure not to lose any washers that may be under bearing, as they adjust the mesh of the gears. When replacing, be sure the screw and cap are tight.

WOLF[®]
1st/Since 1888

THE WOLF MACHINE COMPANY

5570 Creek Road • Cincinnati, OH 45242 • USA

Phone: 513-791-5194 • FAX 513-791-0925

TOLL FREE 1-800-543-WOLF

e-mail: info@wolfmachine.com • Web Site: www.wolfmachine.com

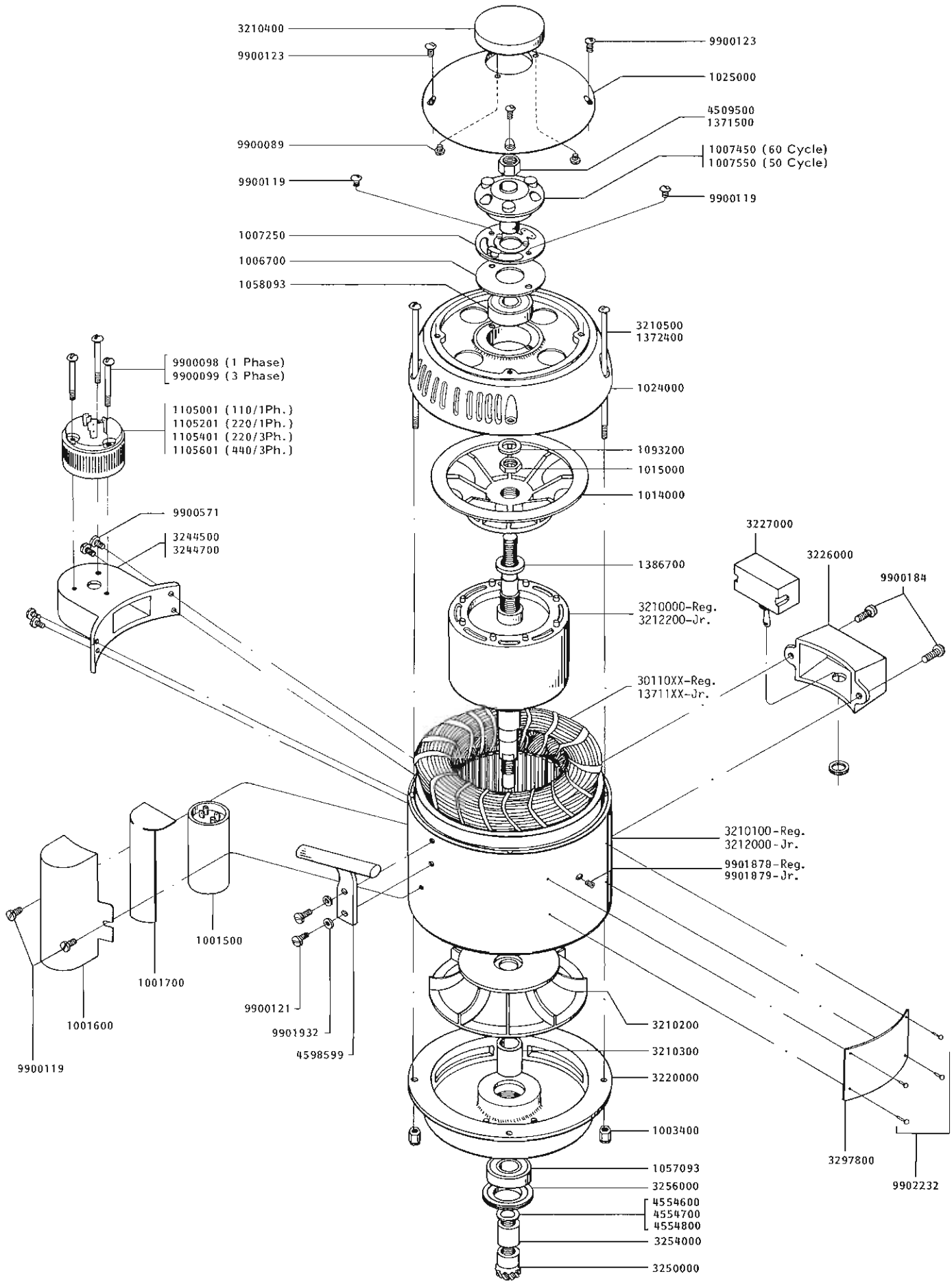

See back cover for part numbers and descriptions.

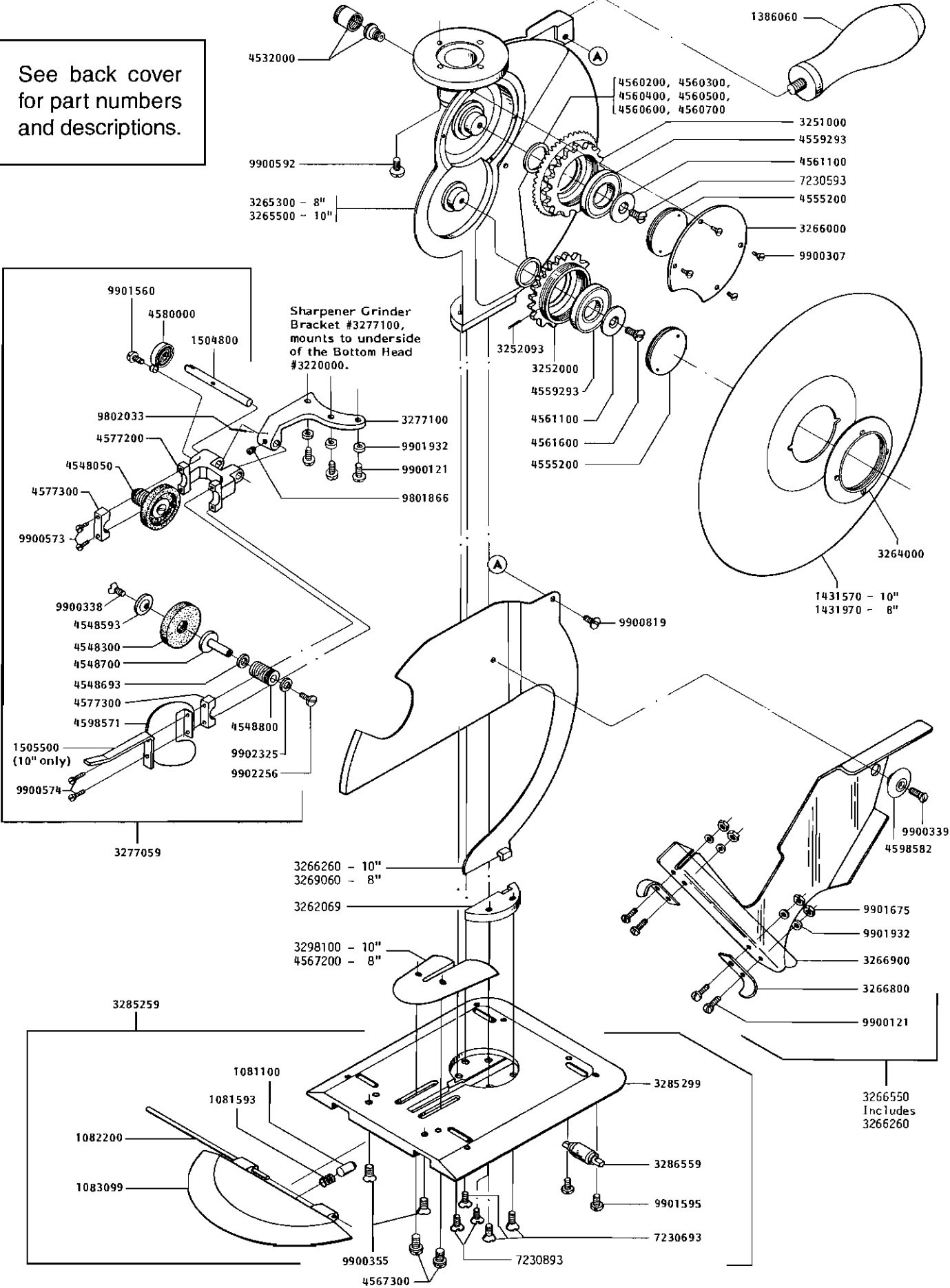

PART NUMBERS and DESCRIPTIONS for ENTIRE MACHINE. Listed in numerical order.

Part No.	Description	Quantity used if more than 1	Part No.	Description	Quantity used if more than 1
1001500	Capacitor - 110V		3269550	8" OSHA Guard Complete (not shown)	
1001600	Capacitor Cover		3277059	Grinder Frame Complete	
1001700	Capacitor Insulator		3277100	Grinder Bracket - 10"	
1003400	Acorn Nut	4	3279200	8" Pull Rod (not shown)	
1006700	Insulator		3285259	Footplate Complete	
1007250	Inner Breaker		3285299	Footplate	
1007450	Outer Breaker - 60 Cycle		3286559	Roller Complete	4
1007550	Outer Breaker - 50 Cycle		3297800	Name Plate	
1014000	Fan - Top		3298100	Toe Plate - 10"	
1015000	Lock Nut		4509500	Nut	
1024000	Top Head		4532000	Grease Cap	
1025000	Cover		4548050	Emery Wheel and Shaft Complete	2
1057093	Bearing for Boftom Head		4548300	Emery Wheel	2
1058093	Bearing for Top Head		4548593	Emery Wheel Washer	2
1081100	Pin for Lifter Spring		4548693	1/4" Nylon Washer	2
1081593	Lifter Spring		4548700	Emery Wheel Shaft	2
1082200	Hinge Pin		4548800	Grinder Journal	2
1083099	Lifter		4554600	Shim .001	
1093200	Bearing Spacer		4554700	Shim .003	
1105001	Male Twist Lock Plug - 1Phase, 110V		4554800	Shim .005	
1105201	Male Twist Lock Plug - 1 Phase, 220V		4555200	Bearing Lock Nut	
1105401	Male Twist Lock Plug - 3 Phase, 220V		4559293	Knife Bearing	
1105601	Male Twist Lock Plug - 3 Phase 440V		4560200	Shim .001	
1371101	Stator Junior - 110/1/60		4560300	Shim .003	
1371104	Stator Junior - 220/1/50		4560400	Shim .005	
1371116	Stator Junior - 220/3/60		4560500	Shim .010	
1371500	Nut - Junior		4560600	Shim .032	
1372400	Motor Bolt - Junior		4560700	Shim .002	
1386060	Handle		4561100	Lock Washer	2
1386700	Rear Fan Spacer		4561600	Left Hand Screw	
1431570	10" Knife Blade - Carbon		4567200	Toe Plate - 8"	
1431671	10" Knife Blade - High Speed		4567300	Screw to secure Toe Plate	2
1431970	8" Knife Blade - Carbon		4576000	8" Grinder Trigger (Not shown)	
1432071	8" Knife Blade - High Speed		4576400	8" Shoulder Screw (Not shown)	
1504800	Grinder Shaft		4577200	Grinder Frame	
1505500	Grinder Handle - 10" only		4577300	Grinder Frame Cap	2
3011001	Stator - 110/1/60		4580000	Grinder Spring	
3011004	Stator - 220/1/50		4598582	Pivot Bushing and Screw	
3011016	Stator - 220/3/60		4598571	Guard	
For any other Stator Voltages, Please Specify.			4598599	Carrier Handle	
3210000	Rotor		7230593	Hardened Screw	2
3210100	Motor Case		7230693	Hardened Screw	3
3210200	Boftom Fan		7230893	Hardened Screw	2
3210300	Boftom Fan Spacer		9801866	Set Screw	
3210400	Rotor Knob Cover		9802033	Roll Pin	
3210500	Motor Bolt	4	9900089	Round Head Screw	2
3212000	Motor Case Big 'O' Junior		9900098	Screw to secure Twist Lock Plug 1 Phase	3
3212200	Rotor Big 'O' Junior		9900099	Screw to secure Twist Lock Plug 1 Phase	3
3222000	Bottom Head		9900119	Round Head Screw	2 & 2
3226000	Switch Box		9900121	Round Head Screw	2, 3 & 4
3227000	Switch		9900123	Round Head Screw	2
3244500	Inlet Box Twist-Lock 1 Phase Plug		9900184	Round Head Screw	2
3244700	Inlet Box Twist-Lock 3 Phase Plug		9900307	Flat Head Screw	4
3250000	Pinion Gear		9900355	Flat Head Screw	2
3251000	Double Gear		9900338	Locking Screw	2
3252000	Knife Gear		9900339	Screw to secure Plastic Guard	
3252093	Gear Pin	2	9900571	Screw to secure Connector Box	4
3254000	Aligning Collar		9900573	Screw	2
3256000	Lock Nut for Bottom Bearing		9900574	Screw - 10" only	2
3262069	Filler Block		9900592	Filester Head Screw	4
3264000	Knife Nut		9900819	Screw to secure Rear Knife Guard	
3265300	Standard - 6"		9901560	Screw to secure Spring	
3265500	Standard - 10"		9901595	Round Head Screw to secure Rollers	8
3266000	Cover for Double Gear		9901675	Nut	4
3266260	Rear Knife Guard Bracket - 10"		9901878	Set Screw	
3266550	10" OSHA Guard Complete		9901879	Set Screw	
3266800	10" OSHA Plastic Guard Bracket	2	9901932	Lock Washer	2, 3 & 4
3266900	10" OSHA Plastic Guard		9902232	Escutcheon Pin	4
3266960	10" OSHA Guard with Bracket		9902256	Screw to secure Journal	2
3269060	Rear Knife Guard Bracket - 8"		9902325	Washer	2
3269200	8" OSHA Plastic Guard (not shown)				